

ELGO LIMAX 2M Mountingkit - Holder GERADE
KW-Nr. 1100711



ELGO LIMAX 2M Mountingkit - Holder GEWINKELT
KW-Nr. 1100712



Mounting of the ELGO-LIMAX-2M System

Installation in the elevator shaft must be carried out in such a way that the contact is primarily created between the steel strip and the polymer guide of the sensor.

Please pay attention to light pretension with defined contact between steel strip and polymer guide. Strong misalignment leads to the destruction of the guide or reading head.

Please refer to the ELGO-LIMAX installation instructions!

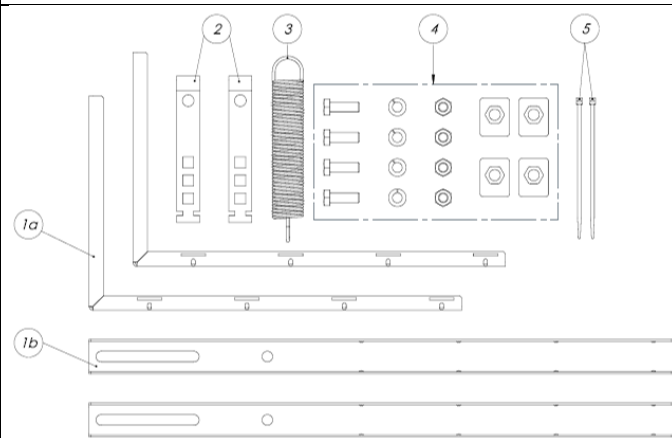

Montage-Set

	Englisch
①a	Crossbeam for "Rucksack" Layout(2x)
①b	Crossbeam for Standard Layout(2x)
②	Tape fixture (2x)
③	Spring (1x)
④	Rail clips including nuts and bolts (4x)
⑤	Cable ties (2x)

1. Mount the shaft flag holder in the shaft head in compliance with legal and company-related safety regulations. Depending on whether you are installing a central rail or rucksack system, use the shaft lugs 1a or 1b and fix it with the attachment set 4 (claws).

2. Fasten the upper end of the tape by inserting the holder 2 into the chute holder 1. Before you insert the magnetic tape, check the orientation of the tape. The printed arrows on the magnetic tape must point towards the shaft head!

The picture on the right shows how the tape is to be inserted into the holder. Finally, the tape end is secured with a cable connector 5.

2. Drive down with inspection and rewind the tape directly. Please provide personal protective equipment recommended for use. Avoid damage to the tape.

4. Drive with the cabin into the center of the shaft and let the entire belt into the pit so that it is freely suspended.

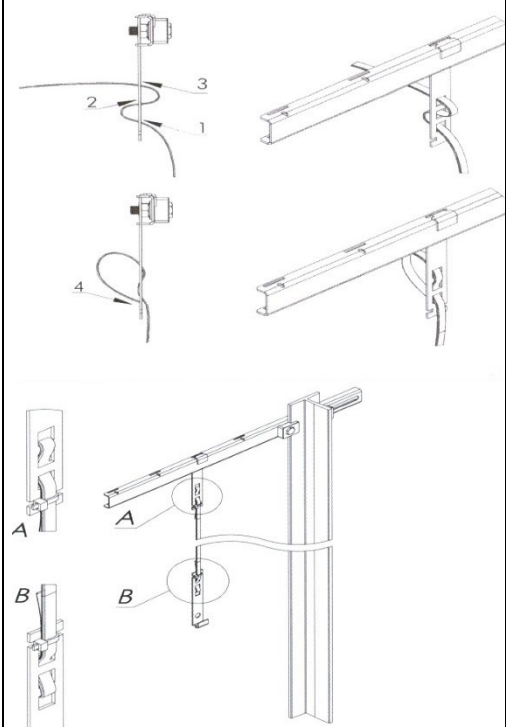

5. The freely suspended magnetic tape shows you the position where you have to mount the sensor on the cabin. The mounting bracket is already pre-mounted on the ELGO-2M sensor and the screw mounting is included. Check again whether the chosen mounting position is suitable.

6. Now pass the tape through the sensor. When using the tape as a reference, align the sensor in the middle.

7. Now adjust the distance between the tape and the sensor. For lifting heights up to 50 meters we recommend a distance of approx. 15mm. This offset ensures that the strip is correctly guided on the steel side during operation. Make sure that the sensor head is mounted vertically. Deviations lead to increased wear.

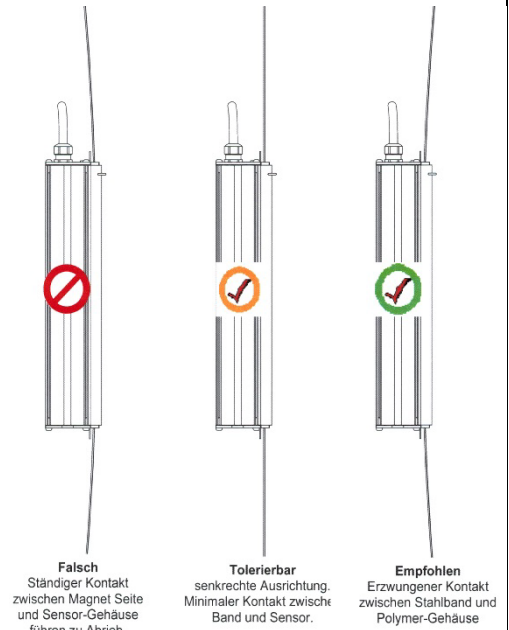

8. Further assembly takes place in the shaft pit. Before entering the pit, ensure that the car is secured against uncontrolled downward movement. When working for more than 15 minutes, be sure to wear the car while observing the safety regulations of the company!

9. Equivalent to Steps 1 and 2, the lower shaft flag holder 1 and the holder 2 for the magnetic tape are to be mounted. Please note that, in deviation from step 2, a tension spring 3 is to be installed! See right picture!

Decisive for the functionality is the spring preload. It should be 265mm!

10. Clean the tape after installation. Use a dry, clean cloth. Start in the shaft head and go down with inspection drive all the way down. Pull the tape through the cloth with light pressure. Avoid the penetration of foreign bodies into the sensor slot!

11. Check the correct mounting. Deviations and angular misalignment must be corrected.

This is best done through an inspection ride through the shaft.

12. This allows the plug of the Variotech ANTS read head to be plugged in without voltage. Subsequently, the switch S37 can be switched on again.

