



## 2,8" RAFFAELLO Display

### Contents

[Safety and usage cautions](#)

[Mounting](#)

[Wiring Instructions](#)

[POSITION & DIRECTION Input Wiring](#)

[SERVICE MESSAGE Wiring](#)

[Settings](#)

[Datasheet](#)

[Raffaello 2,8"](#)

[Video Tutorial](#)

[Download](#)



(v 1.2)



 To check and download all versions of this guide, go at the [following link](#).

✓ Updated to EN81-28:2018 regulation.



## Safety and usage cautions

Before installing our products, we recommend you to consult the section about safety and usage cautions at the link below.



## Mounting

⊖ Raffaello 2.8"

With welded pins on 1,5÷2 mm pushbutton panel

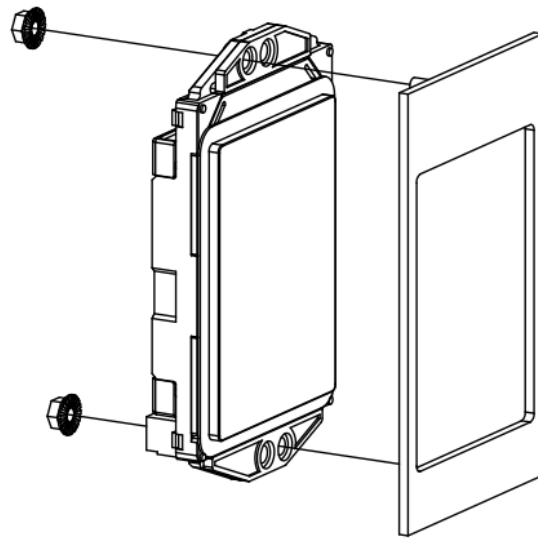
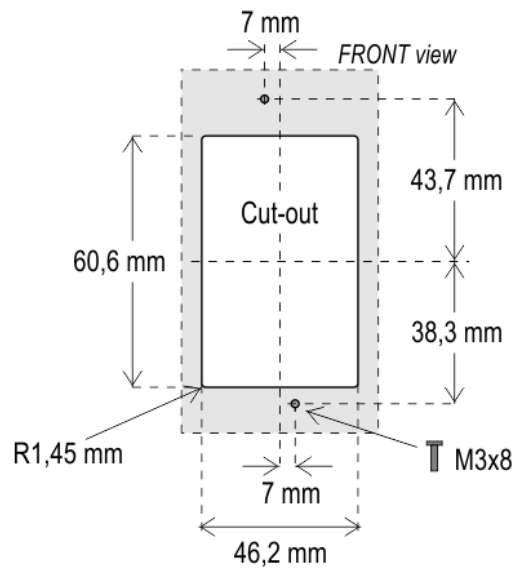

**With pins on backplate (for 1 mm pushbutton panel)**

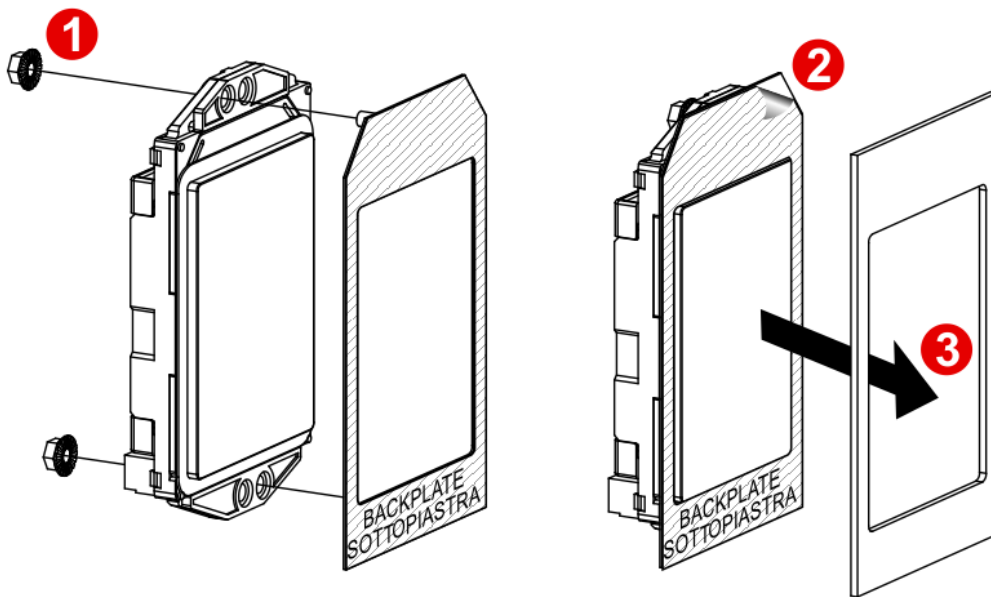
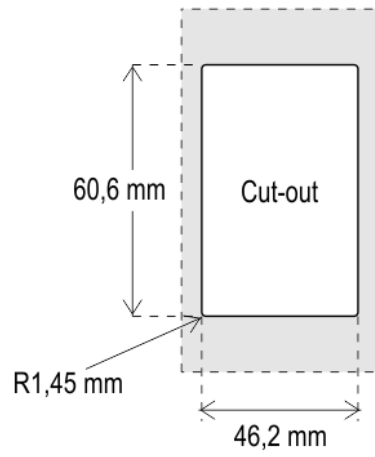

⊖ Raffaello 2.8''  
(EN81-71)

With welded pins on 2÷3 mm pushbutton panel

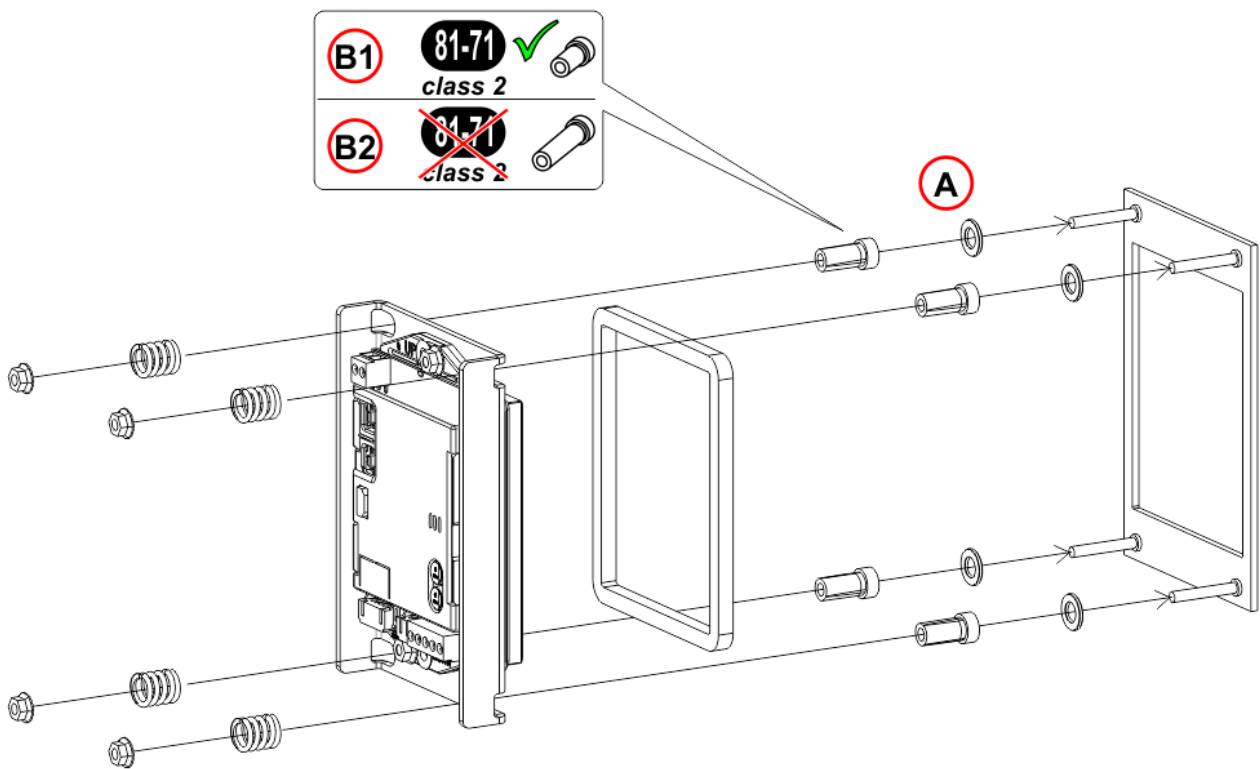
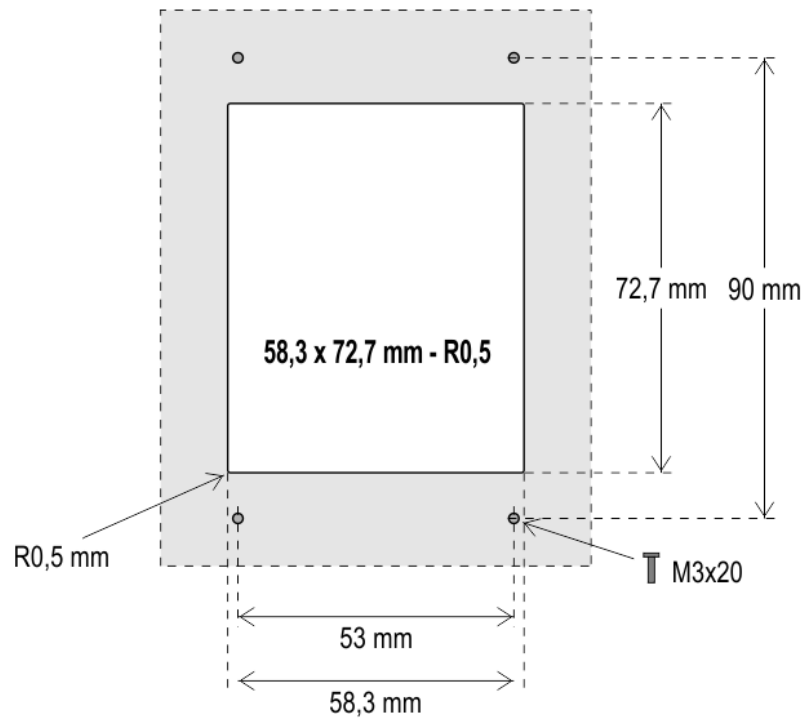

- A) – 2mm thicknes plate only
- B1) – For 2mm/3mm thicknes plate
- B2) – For 1,5mm thicknes plate

## Wiring Instructions

# POSITION & DIRECTION Input Wiring

## ← Pitagora 4.0

DMG CAN serial protocol

CAR

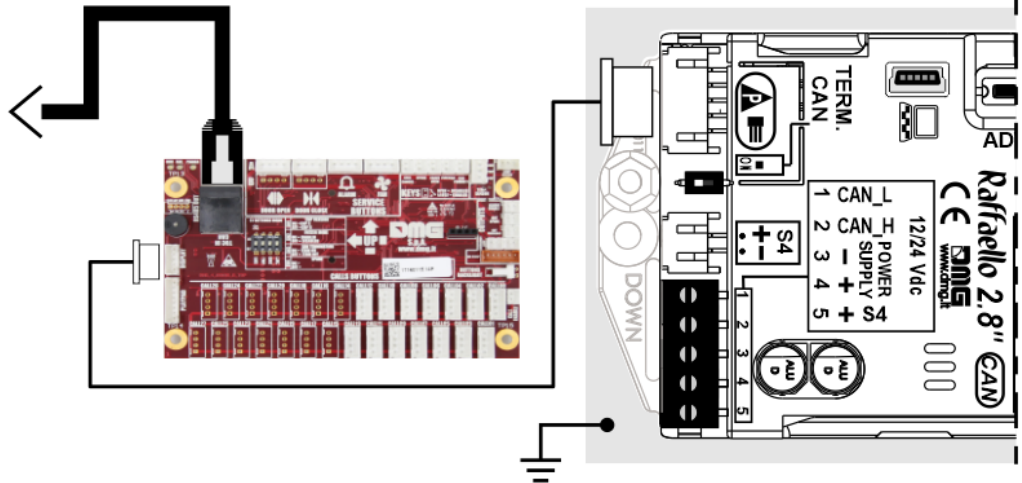

FLOOR

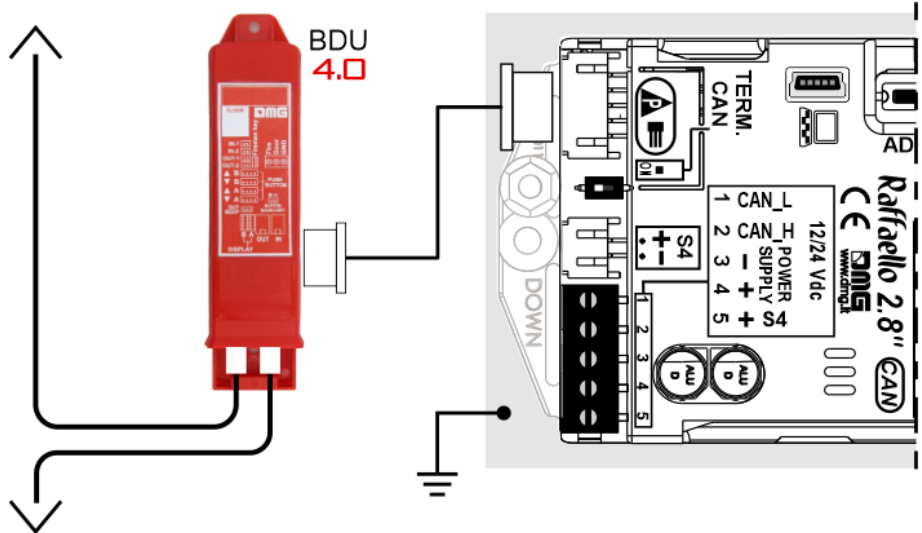

DMG

3-wires serial

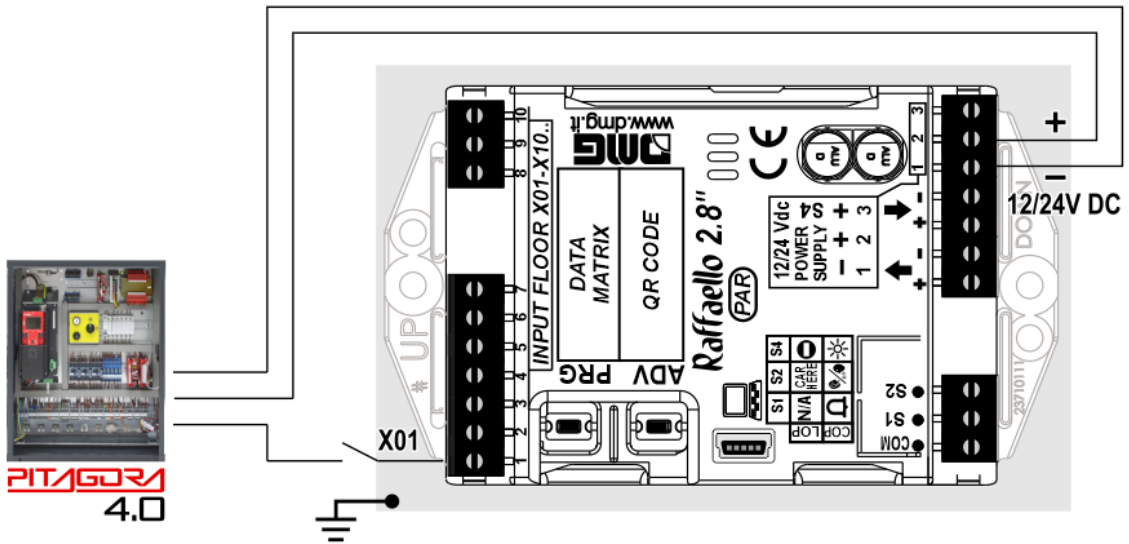

## Encoder DEUM



For more details please refer to the [Encoder DEUM](#) support page

DMG

CAN serial protocol

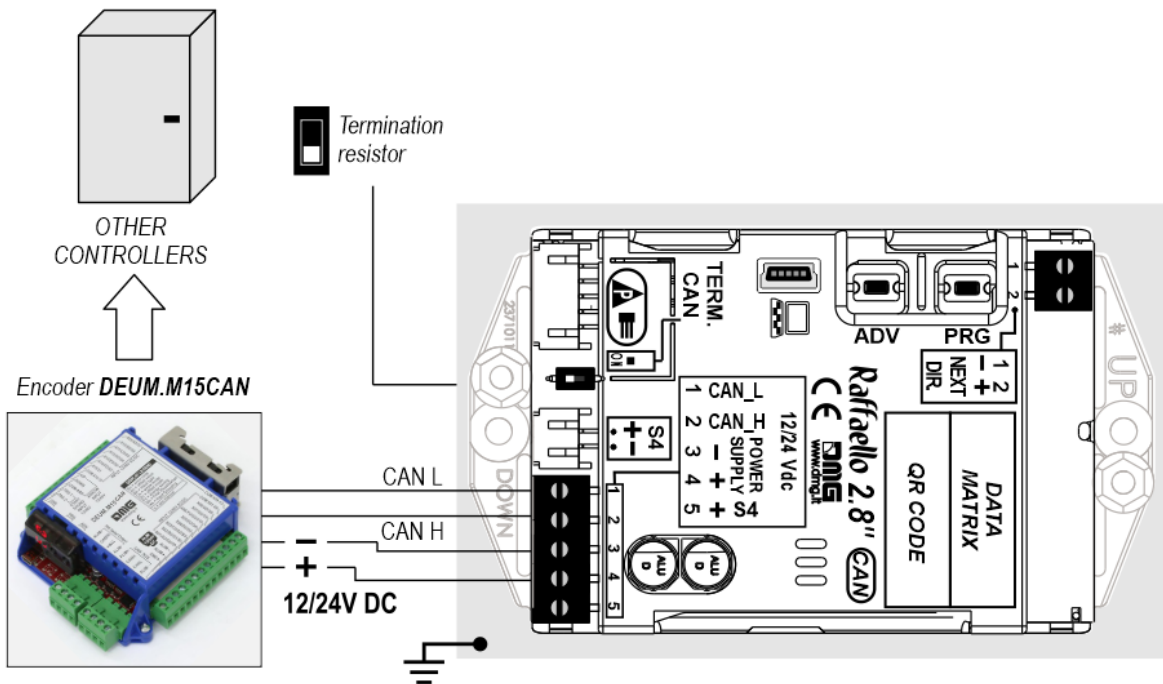

**TERM.CAN**



Activate the CAN line termination both on the elevator car position indicator and the last position indicator of floor.

# DMG

## 3-wires serial

Encoder DEUM.M15CAN  
Encoder DEUM.M15S3W

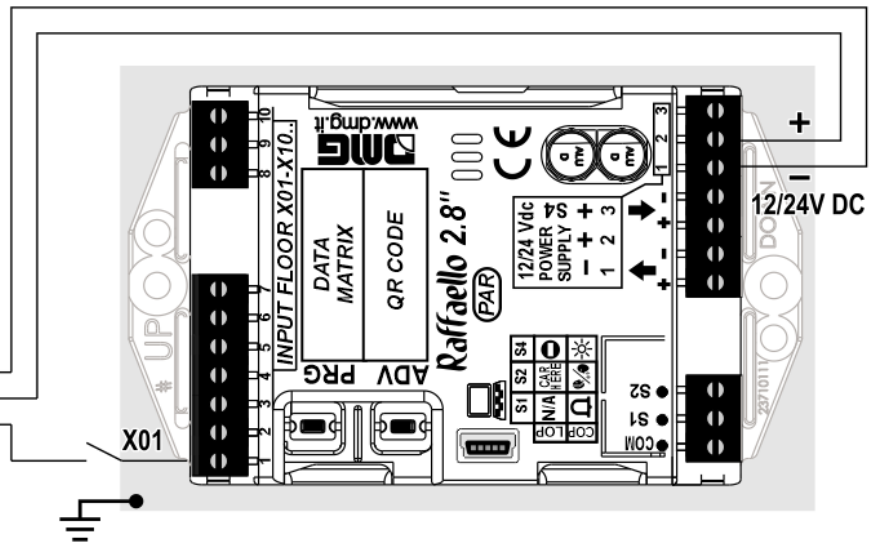
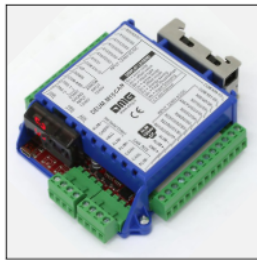

## Other Controllers

### Proprietary CAN protocol

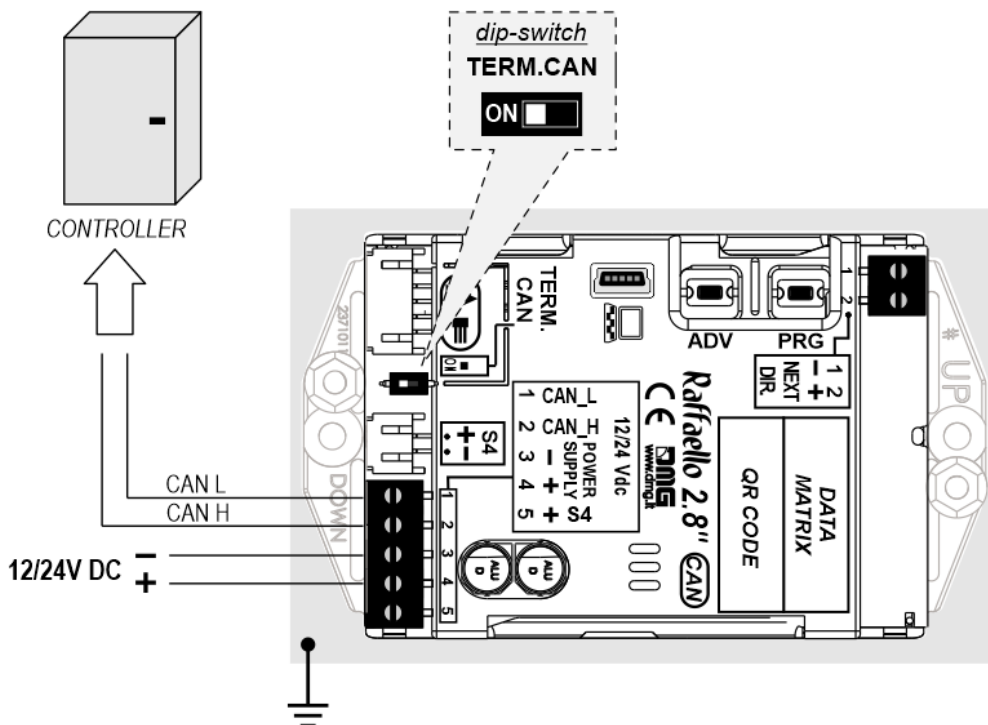

### TERM.CAN



Activate the CAN line termination both on the elevator car position indicator and the last position indicator of floor.



# 1 Wire / Floor

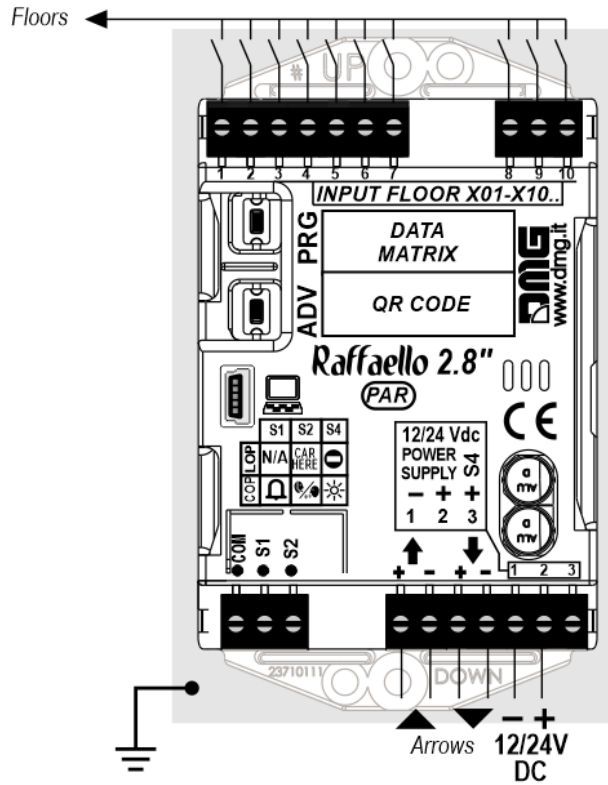

10 floors max.

# 1 Wire / Segment

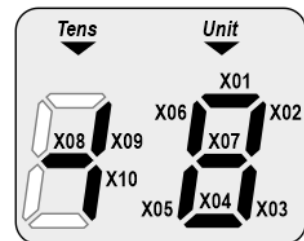
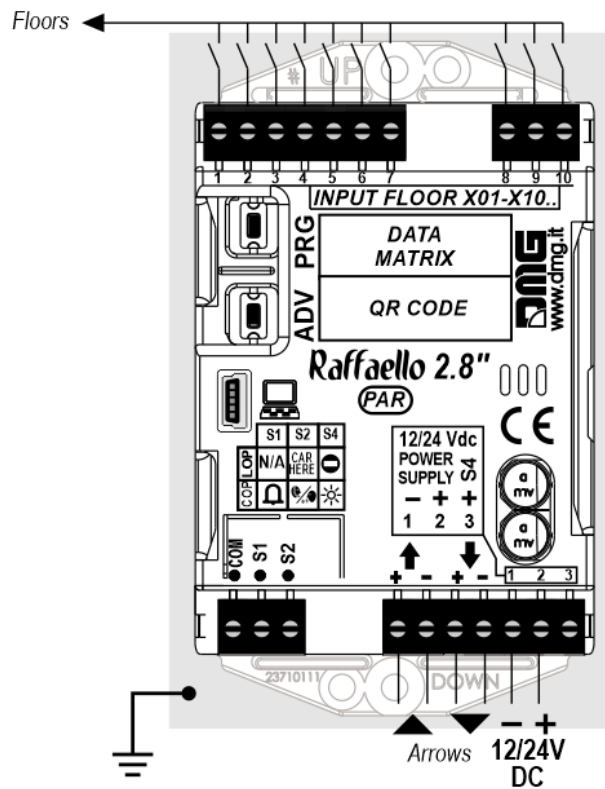



29 floors max. (-9, 0, 19)

### Gray / Binary

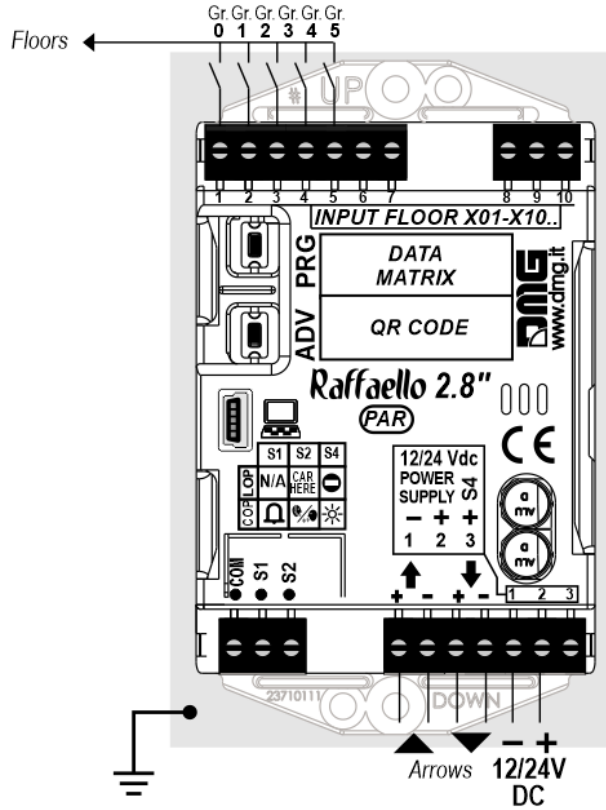

72 floors max. (-9, 0, 62)

### TKE/MEA/Autinor

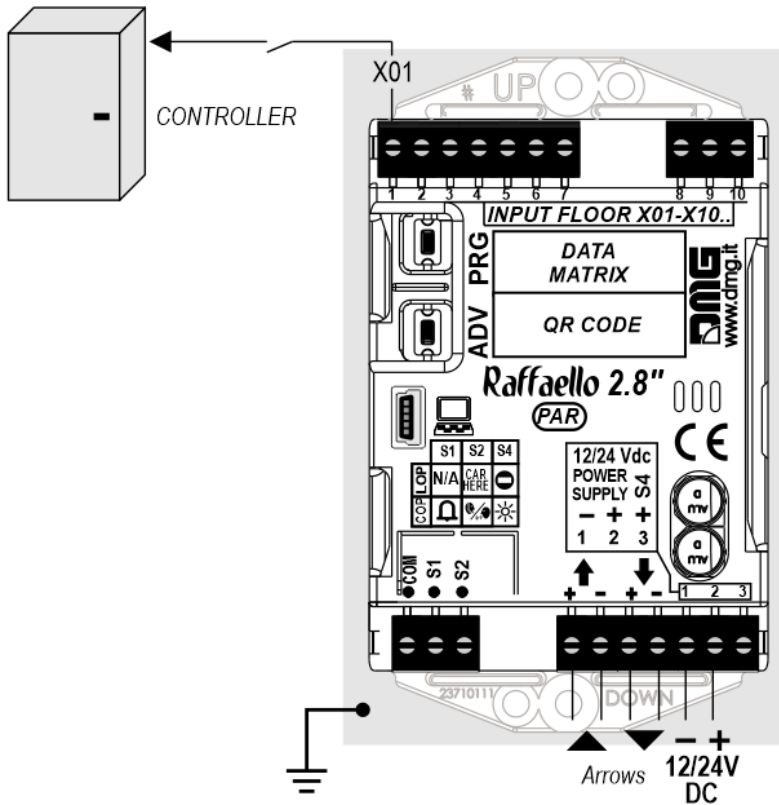

## SERVICE MESSAGE Wiring

*Parallel display*

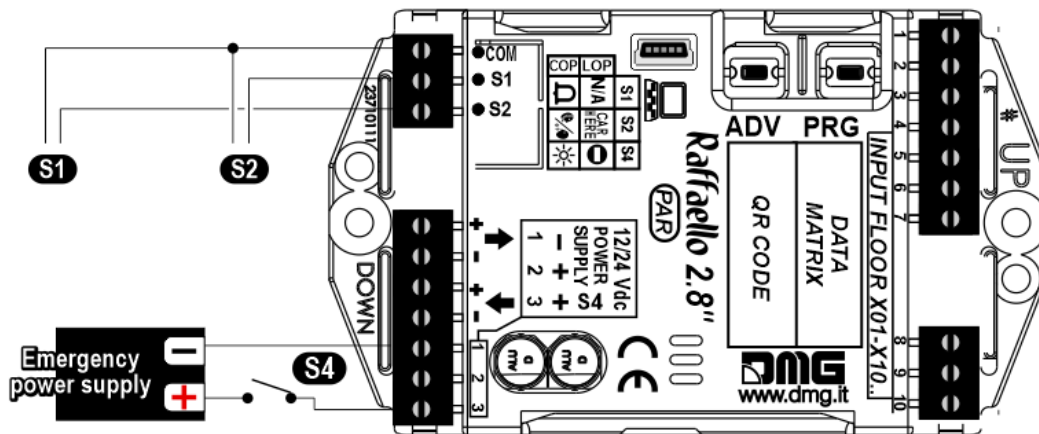



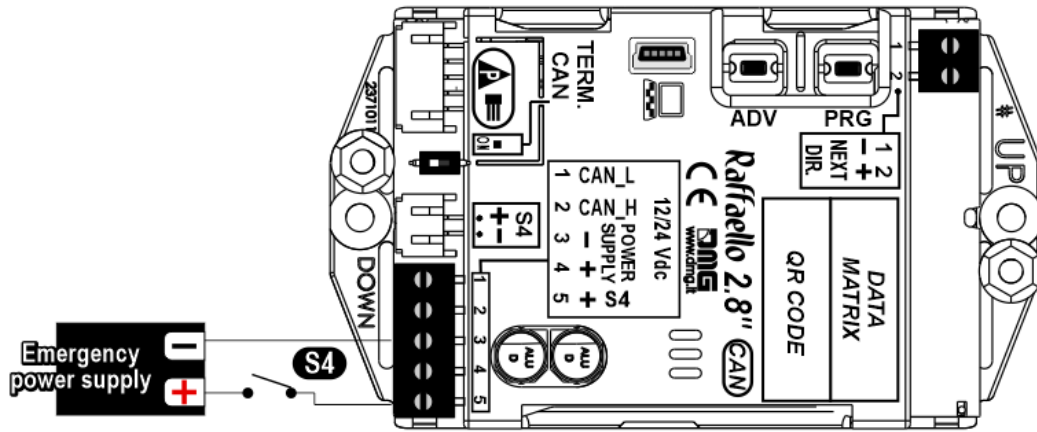



*CAN serial display (\*)*



(\*) – Service messages can also be piloted, through serial bus, in two different ways:

- by controller DMG
- by encoder **DEUM.M15**

	Car	Floor
S1	 Alarm sent	 Allarme (legge 13)
S2	 Communication established	 Car here
S4	 Antipanic light	 Out of service

## Settings

 <b>ADV</b> <i>Setup Key</i>	 <b>ADV</b> <i>Exit / Back</i>	 <b>PRG</b> <i>Access Menu Key</i>	 <b>PRG</b> <i>Value setting (&gt;3 sec.)</i>
---	---	---	--

*Navigation menu keys*

– General



The display navigation menu is in English only; to see the correct menu items we recommend setting the DIDO website language to English.

MENU	MENU ITEM		AVAILABLE CHOICES	INPUTS	
				Parallel	CANE
Input			Serial / 1 wire per floor / segment Gray / Binary / Pos.Sensor TKE / MEA / Autinor / CAN DMG	•	•
Options	Interface Options	Display Configuration	COP / LOP / LIP	•	•
		Arrow Configuration	Direction / Next Dir.		•
		Car at Floor	No / Yes		•
		CAN Baudrate	250k, 125k, 10k, Auto		•
		Convert Mezzanine	No / Yes		•
		Offset Value	-9 / ... / 0 / ... / +9	•	
		First Visualization	Blank / Zero	•	
		Common Selection	Negative / Positive	•	
		Arrow Type	Fixed arrows / Scrolling arrows	•	

MENU	MENU ITEM		AVAILABLE CHOICES	INPUTS		
		Enable AUX Signals	10 + 0 / 6 + 4	•		
		Input Filtering	0 ... 20	•		
		Screensaver timer	Disabled / 10-20 / 30-60 / 60-120	•	•	
	Graphic Options	Font		Dado / Classic Bold / Lagoon / Dot Matrix	•	•
		Flat Style	Symbol color	White / Red / Orange / Blue / Gray / Black	•	•
			Background color	Black / Pacific Blue / Navy Blue / Reef Blue / Light Gray / White / Orange / Red	•	•
			Specials	White-Green / White-Lilac / Purple-Yellow / White-Gray	•	•
		Gradient Style	Style	Black & White / Red Passion / Gray Goose / Blue Shades	•	•
			Color	Galaxy / Ocean Dream 2/1 / Reef Blue / Purple haze / ...	•	•
		Floor Symbols		Show / Hide	•	•
		Arrows		Show / Hide	•	•
		Fixed Symbols Positions		No / Yes	•	•

MENU	MENU ITEM	AVAILABLE CHOICES	INPUTS	
	Filter Blinking Signals	No / Yes	•	•
	Message Mode	Alternating / Fixed	•	•
	Orientation	Landscape (Horiz.) / Portrait (Vert.) / Rev.Landscape / Rev.Portrait	•	•
	Signal Inputs Configurations	Input S1 / S2 / S4	•	•
	AUX Signals Configurations	AUX Signal 1 / 2 / 3 / 4	•	•
	Reset All Settings		•	•
?	DEMO mode	No / Yes	•	•
	Firmware Version / Life Time (internal use)		•	•
Floor Numbers	Numbers / Letters	Choose the Numbers / Letters	•	

## — Coding

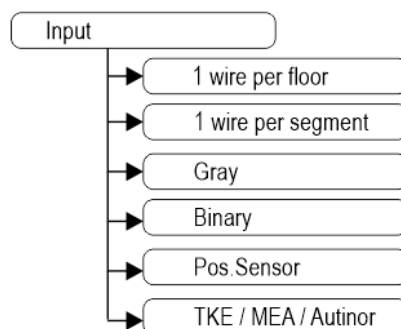

## — Set up Raffaello as elevator car indicator or floor indicator

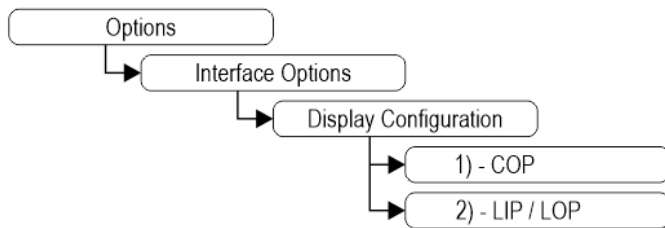

1) – Elevator car Position Indicator (default)

2) – Hall Position Indicator

## ➡ Arrow setting up

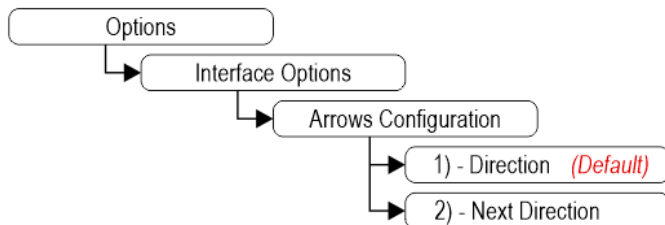

1) – Direction arrows (default)

2) – Next direction arrows (instructions below)

### Next Direction Arrows enabled from input

Arrows light up only on the position indicators with the “NEXT DIRECTION” input powered.

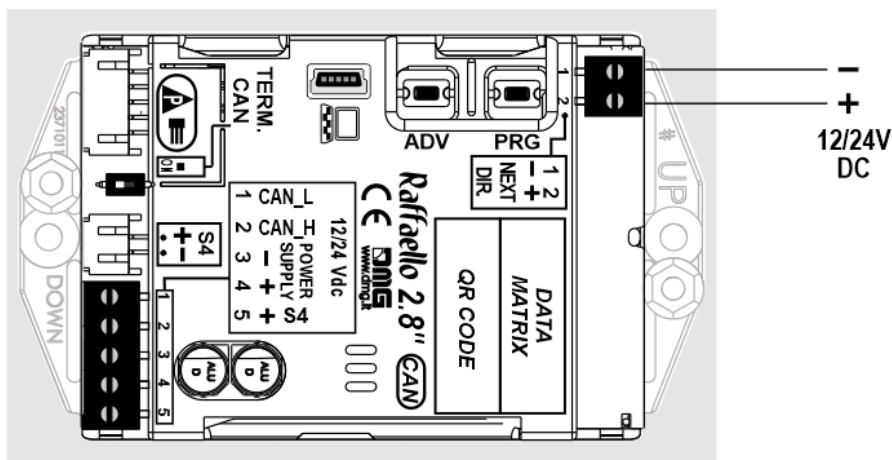

If the **DEUM Encoder** is used, please refer to the relevant manual

### Next Direction Arrows locally programmed



Through the addressing procedure one can permanently assign to each indicator the information of the floor on which it is mounted; in this way, next direction arrows only light up at the floor where the elevator car is positioned.

– Addressing procedure

- 1) – Connect all position indicators to the ENCODER or PLAYBOARD controller.
- 2) – Position elevator car on the floor of the Display which needs to be directed.
- 3) – Verify that the characters/numbers/letters visualized are the desired ones.
- 4) – Press and hold the ADV key and wait for the display to flash for 3 seconds to confirm.
- 5) – Repeat procedure for each floor.

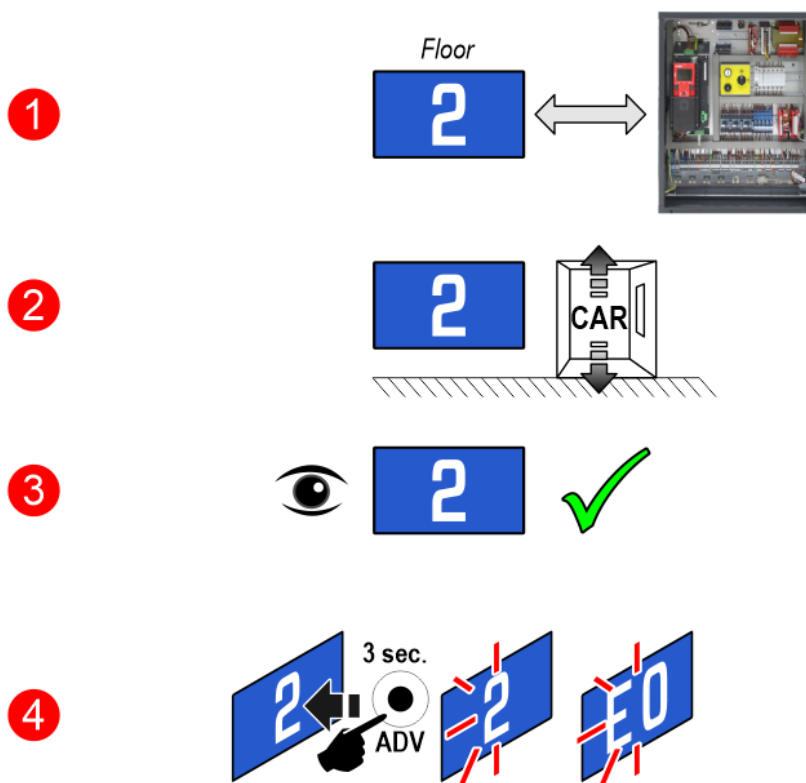

If the **DEUM Encoder** is used, please refer to the relevant manual

– Set up CAN BUS protocol transmission speed

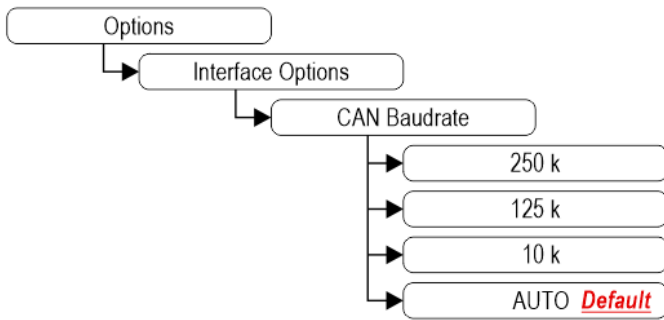

### Intermediate floors visualization

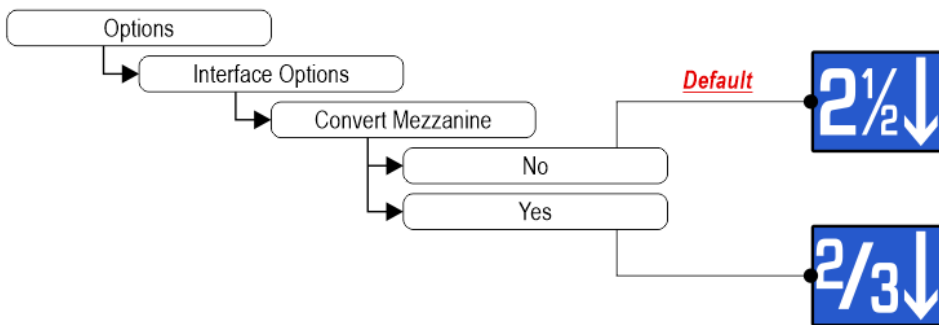

### Set up floors OFFSET

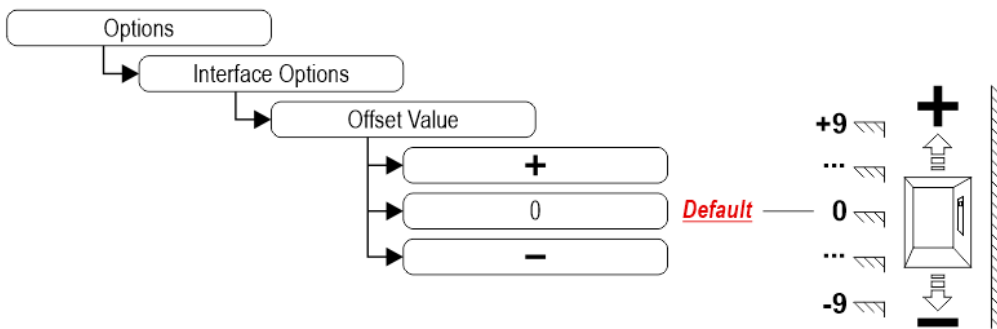

### Set up first visualization

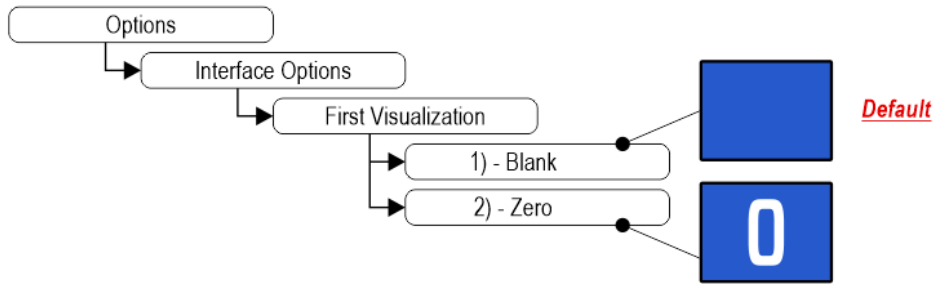

- 1) – It does not display any numbers
- 2) – Lowest floor

### – Set up Parallel position common input

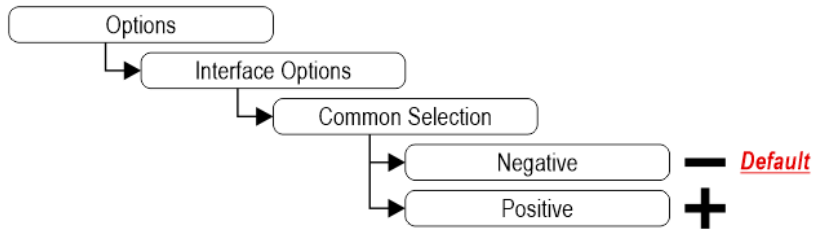

### – Set up scrolling arrows

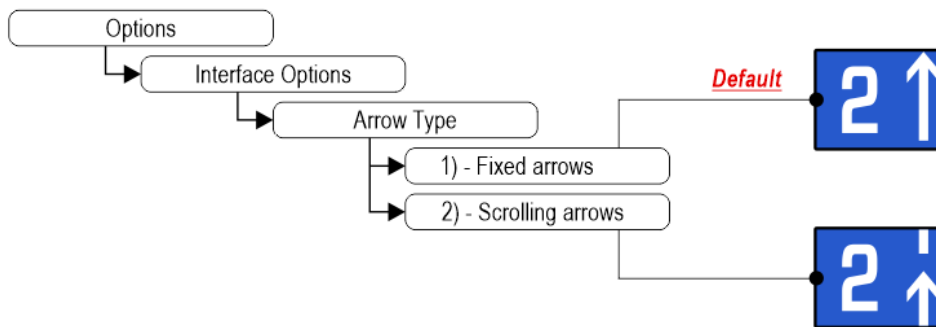

- 1) – Fixed arrows
- 2) – Scrolling arrows

### – Enable auxiliary signals

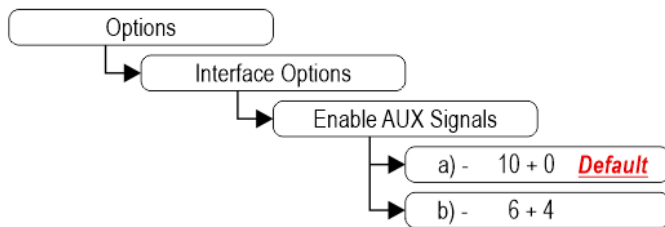

a) – 10 Floor parallel inputs (X01÷X10) + 0 AUX Signals

b) – 6 Floor parallel inputs (X01÷X06) + 4 AUX Signals (X07÷X10)

### – Set up the display delay of floor change

The display delay helps avoiding visualization errors during floor change.

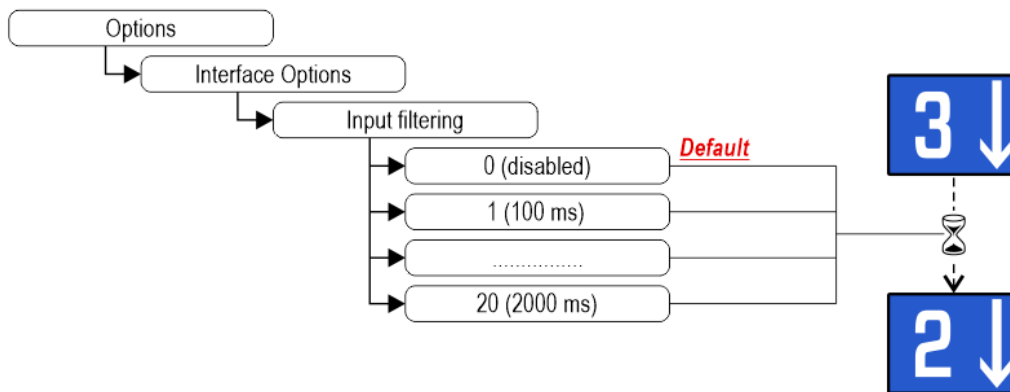

### – Associate the floor position indicator with the duplex controllers

The parameter allows to assign the display (floor) to a unique controller. The Duplex-Light typology includes 2 controllers with a single BDU line and a maximum of 2 displays at the main floor.

This parameter can only be set with the CAN protocol on the Pitagora 4.0 system.

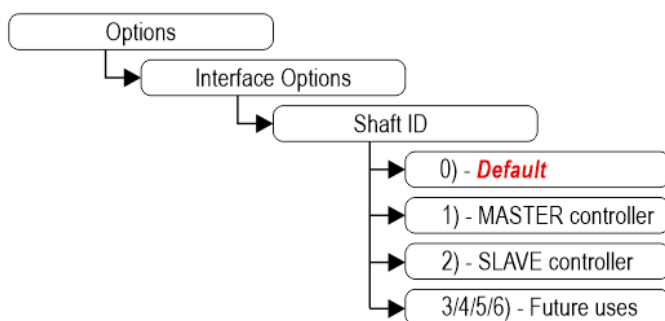

0) – To be associated with the lift car position indicator.

1) – The display will show the information of the MASTER controller.

2) – The display will show the information of the SLAVE controller.

3/4/5/6) – Future uses.

### – Enable energy saving function

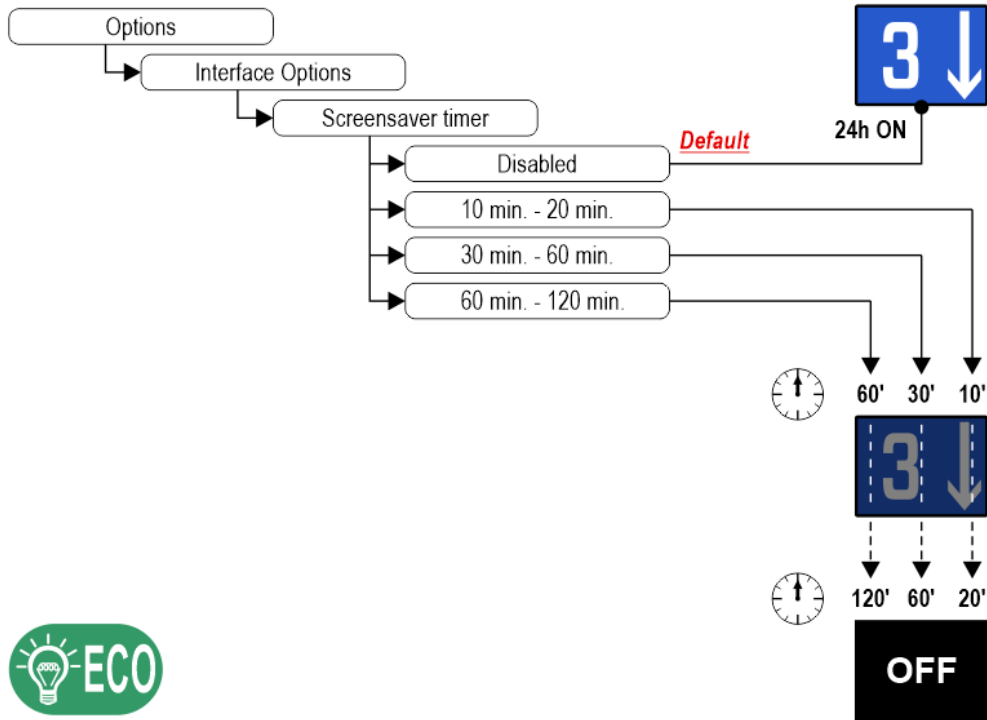

*“Energy saving” mode to reduce consumption when idle.*

### – Set up Font

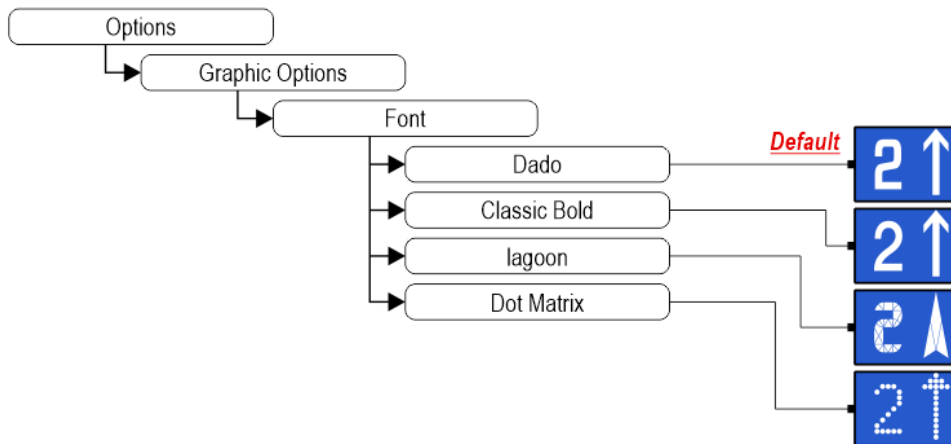

### – Set up flat Style Color

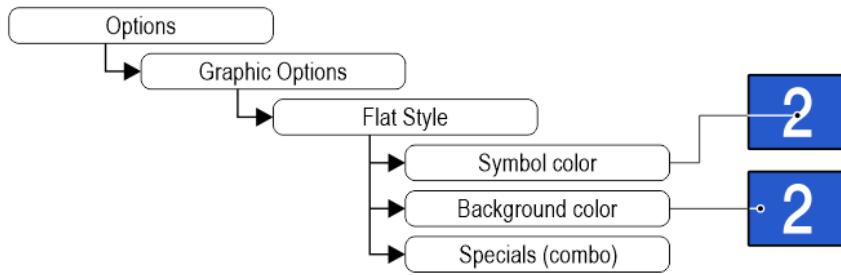

– Set up gradient Style Color

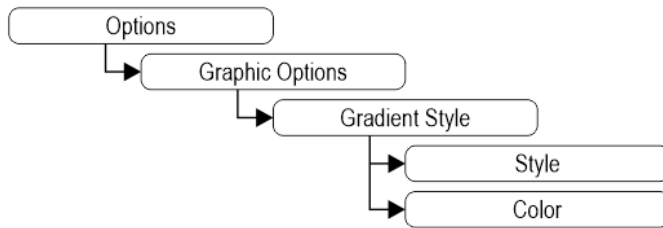

– Show/Hide position

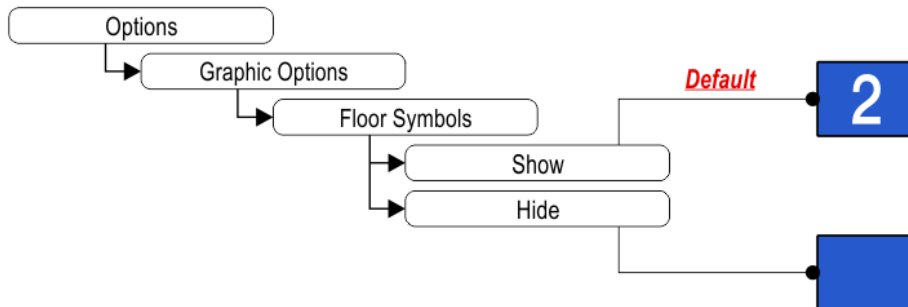

– Show/Hide arrows

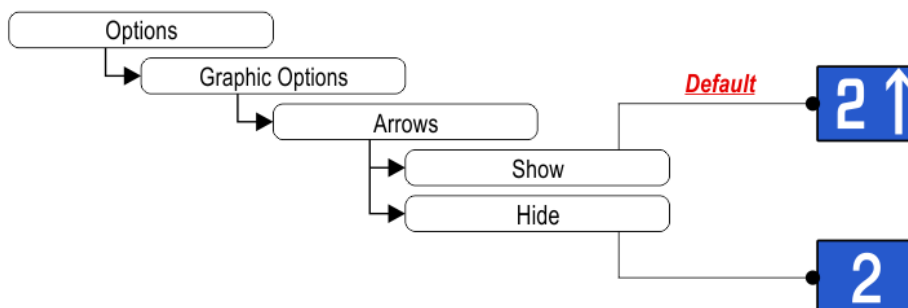

## – Set up Symbols position

*Landscape orientation modes only.*

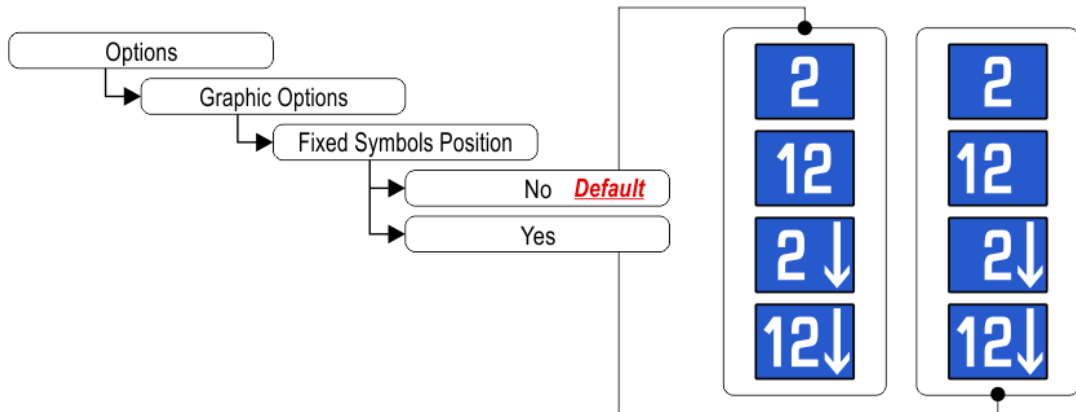

*If “Yes”, the symbols will stay in fixed positions independently of the arrow status.*

## – Signalizations (visualization)

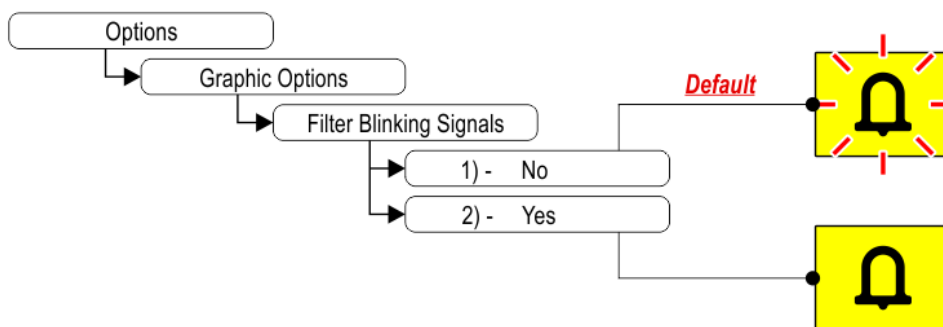

1) – Fixed or blinking signalizations (input from controller).

2) – Fixed signalizations.

## – Set up Viewing mode signalization

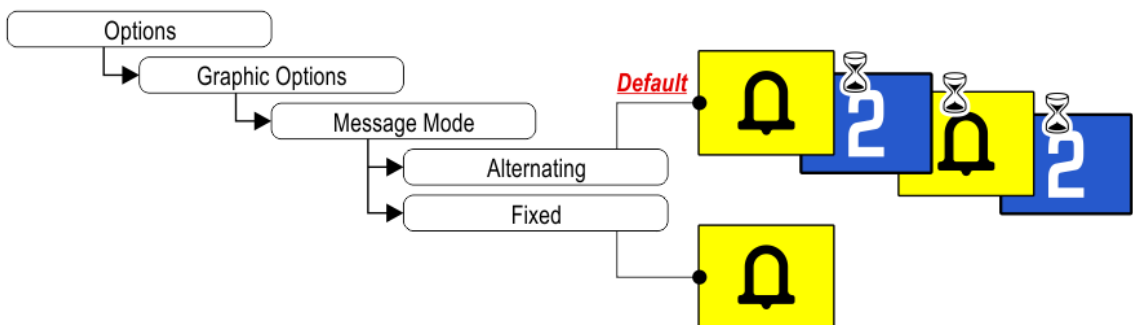

## – Set up Display orientation

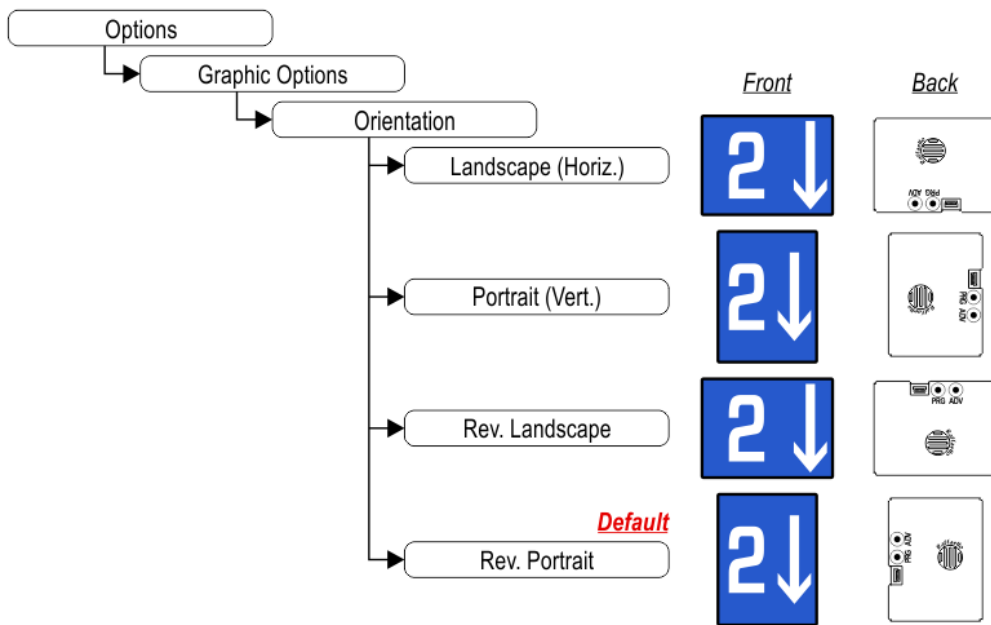

Portrait version: For vertical LIP use only.

## – Set up service message inputs

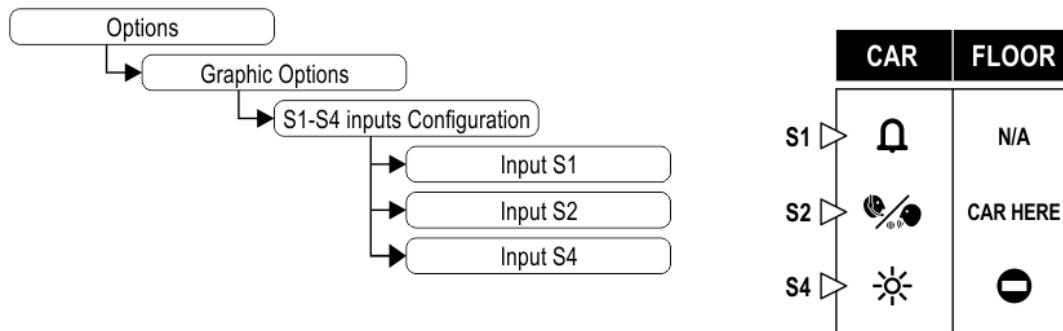

## – Set up auxiliary signal

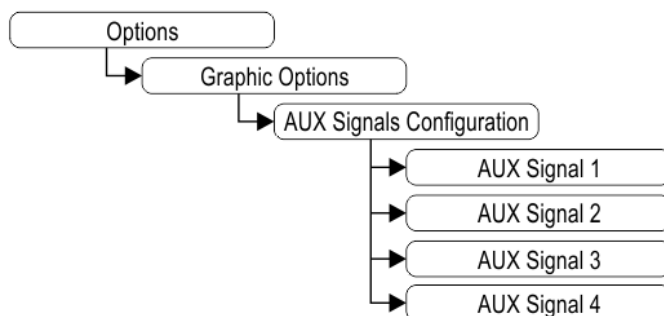



## – Restore the factory settings

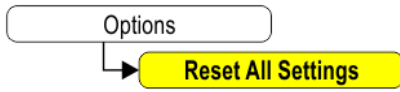

The display original factory settings will be restored and configurations will be deleted.

## – Floor customizations

### 1) Car at floor

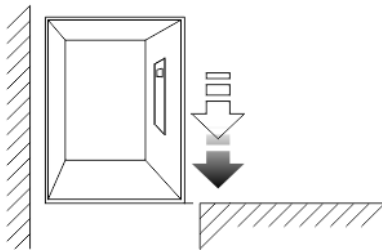

### 2) Set up Floor Numbers / Letters

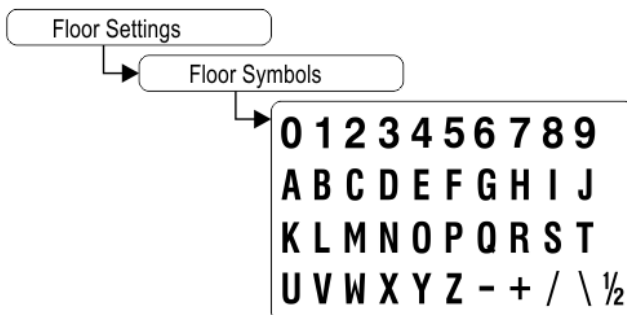

## Raffaello 2,8"

<b>Dimensions</b>	90x60xh20 mm 100x67xh26 mm (EN 81-71)
<b>Screen (Viewable area)</b>	57,6×43,2 mm / 320×240 pixel
<b>Power supply (position input)</b>	12÷24V DC ±10%
<b>Absorption</b>	<i>DISPLAY</i> 12V DC: Max 63mA • 24V DC: Max 46mA <i>PANIC LIGHT</i> 12V DC: Max 60mA • 24V DC: Max 31mA
<b>Indicators inputs</b>	S1 / S2 / S4: 12÷24V DC ±10% (opto-isolated) Impedance = 3Kohm
<b>Operating temperature</b>	-10°C ÷ +50°C

## Video Tutorial

*The graphics parameters configuration*

Raffaello - The graphics parameters configuration



*Offset value*

Raffaello - Offset value



*The common programming*

Raffaello - The common programming



# Download

Reference	Version	Link
Bug fixed on datasheet	1.1	<a href="#">Download PDF (English)</a>
Wiring error correction	1.2 (current version)	<a href="#">Download PDF (English)</a>

Updated on 2 Dicembre 2022