

**ELGO LIMAX CP33 Mountingkit - Holder GERADE
KW-Nr. 1100727**



**ELGO LIMAX CP33 Mountingkit - Holder GEWINKELT
KW-Nr. 1100729**



Assembly of the ELGO-LIMAX-SAFE-CP33

The ELGO LIMAX CP33 is an absolute measuring system for determining the position of the elevator car, consisting of the reading head, the steel belt and the fixing set.

The measuring system can work at a shaft height of up to 100m and a maximum speed of 4.0 m / s with a millimeter resolution. The magnetic tape is fixed with shaft tab holders in the upper and lower part of the shaft. Above the below shaft flag holder a shaft flag holder is attached to the belt breaker. It is important to pay attention to the correct spring preload. Passed through a gap in the reader on the magnetic tape



Please also note the ELGO-LIMAX installation instructions!

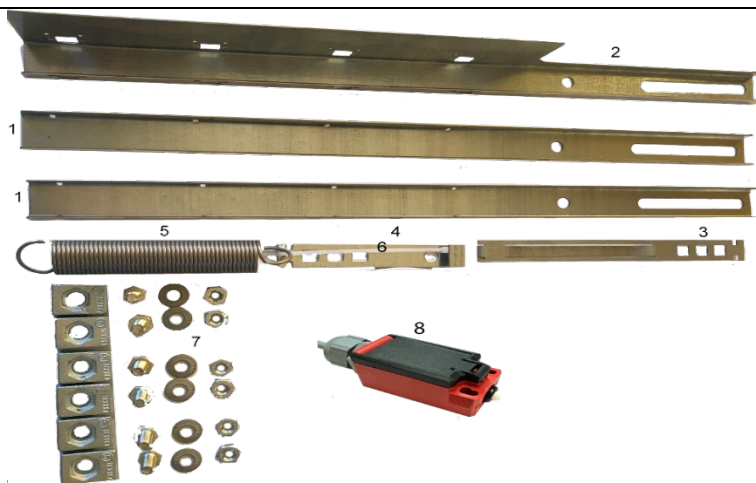

Mounting-Set

Assembly kit complete:

- 0 Reader with mounting bracket
- 1 2x Shaft flag holder for top & bottom
- 2 1x Shaft flag holder for Bandabrissschalter
- 3 Bandholder below for Bandabrissschalter
- 4 Top band holder
- 5 Tension spring
- 6 2x cable ties
- 7 6x screws, u-washer, nuts & Clamping claws
- 8 Tape breaker with cable and attachment
- 9 Magnetic tape

1. Mount the shaft flag holder 1 in the shaft head in compliance with the **legal and company-related safety regulations**. With fastening set 4 (clamps) with a tightening torque of 20 Nm.

2. Attach the top end of the tape by inserting the holder 4 into the shaft flag holder 1. Before inserting the magnetic tape, please check the orientation of the tape. **The printed arrows on the magnetic tape must point to the shaft head!**

The image to the right shows you how to insert the tape into the holder. Finally, the band end is secured with a cable tie 6.

3. Go down with inspection and unwind the tape directly. Please wear the personal protective equipment recommended for use. Avoid damage to the tape.

4. Drive the cabin into the middle of the shaft and let the entire belt into the shaft pit so that it hangs freely.

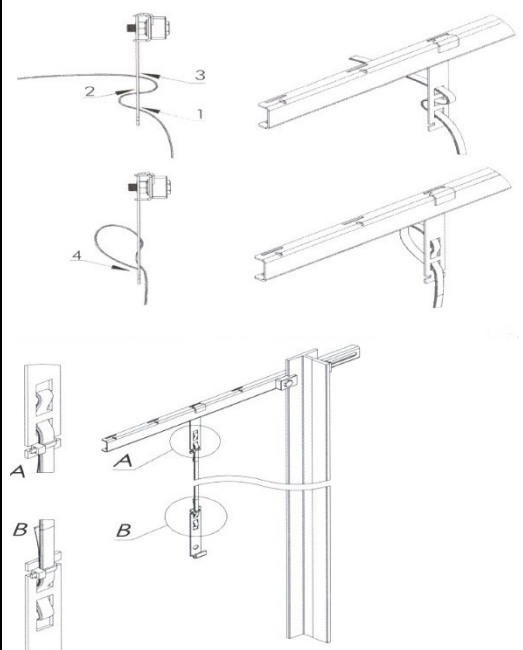

5. The freely suspended magnetic tape shows you the position where you have to mount the sensor on the cabin. The mounting bracket is already pre-mounted on the ELGO-CP33 sensor and the screw mounting is included. Check again whether the chosen mounting position is suitable.

6. Now pass the tape through the sensor. When using the tape as a reference, align the sensor in the middle.

7. Now adjust the distance between the tape and the sensor. For lifting heights up to 50 meters we recommend a distance of approx. 15mm. This offset ensures that the strip is correctly guided on the steel side during operation. Make sure that the sensor head is mounted vertically. Deviations lead to increased wear

8. Further assembly takes place in the shaft pit. Before entering the pit, ensure that the car is secured against uncontrolled downward movement. When working for more than 15 minutes, be sure to wear the car while observing the safety regulations of the company!

9. Equivalent to steps 1 and 2, the lower shaft flag holder 1 and the holder 3 for the magnetic tape to be mounted. Please note that deviating from step 2 the space for a tension spring 5 must be provided! See right picture!

You need a space of 295mm.

10. Before you attach the spring, you must mount the shaft flag holder 2 with the belt breaker 8. The final location will be determined later.

11. Now you can hook in the spring 5. Decisive for the functionality is the spring preload. **It should be 295mm!**

12. Now it goes on with the exact installation of the strip breaker 8:

The tape breaker is used to detect a tearing of the magnetic tape. The plunger of the switch is pushed in by the lower band holder and locks in this position. As a result, the safety circuit is permanently interrupted.

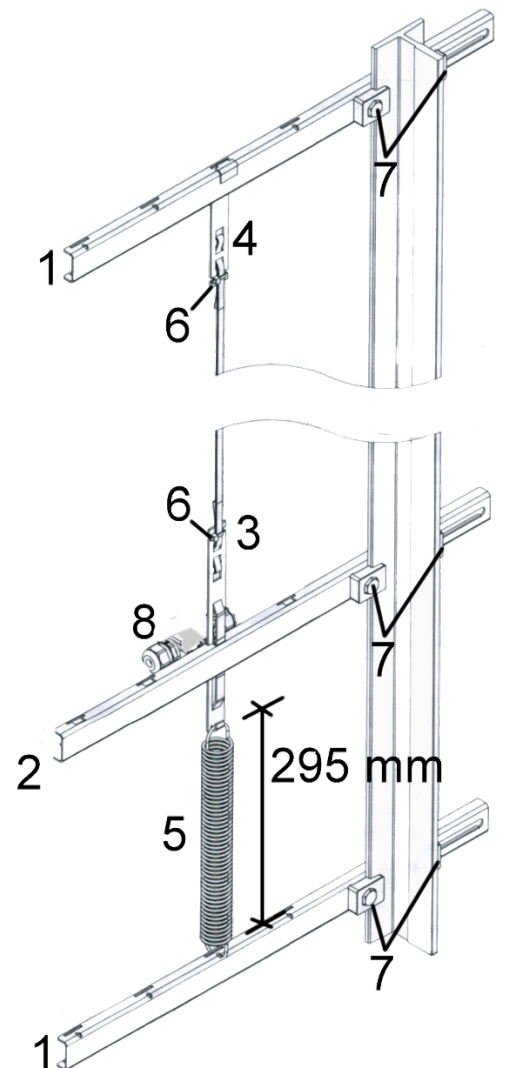
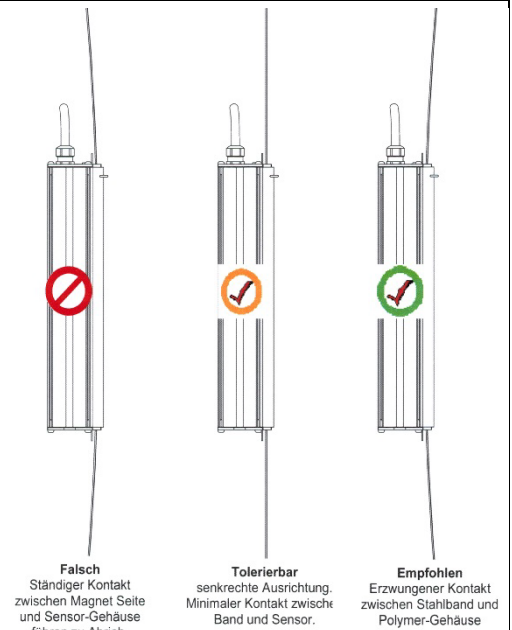

<p>13. The <u>belt breaker</u> 8 is operated by the groove in the lower <u>belt holder</u> 3. Please fasten the belt breaker on the shaft lug holder. The shaft flag holder with the belt breaker is now positioned so that a mark on the belt clip is visible upwards and one downwards. The shaft flag holder is to be tightened at a 90 degree angle with a tightening torque of 20 Nm.</p>		<p>14. Subsequently, the <u>band breaker</u> 8 is set sharp. To do this, carefully remove the plunger (actuator) with a screwdriver</p>	

Electrical Connection:

<p>15. In the shaft pit / shaft pit box: Inserting the belt breaker cable with the wires 1-> 2D and 2-> 2E.</p>	<p>16. On the elevator car / inspection box: Plug in the SCA cable with the 715-PE-716 plug and the 2Z-3 plug.</p>	<p>17. In the inspection box: Plug in the POI cable with the 2 pre-extended terminals.</p>



Attention!

18. Ground the sensor with the grounding cable provided by mounting the sensor with the flat plug and the other end in the inspection box on PE!

Control & Care:



19. Clean the tape after installation. Use a dry, clean cloth. Start at the head of the shaft and take the inspection trip all the way down. Pull the tape gently through the cloth. Avoid the penetration of foreign bodies into the sensor slot!

20. Check the correct installation. Deviations and angular misalignment must be corrected. An inspection trip through the shaft is the best way to do this.